



Job Name: \_\_\_\_\_

Type: \_\_\_\_\_

Part #: \_\_\_\_\_

Notes: \_\_\_\_\_

# LSHPEM

## High Performance LED Emergency Unit

STANDARD

OPTIONAL



### ILLUMINATION

- Long lasting, efficient, ultra bright white LED lamp heads.
- 12W (12 LEDs x 1.0 Watt) per head.
- Adjustable LED lamp heads provide optimal center-to-center spacing.

### ELECTRICAL

- Dual 120/277 voltage.
- Charge rate/power "ON" LED indicator light and push-to-test switch for mandated code compliance testing.
- 9.6V maintenance-free, rechargeable lithium iron phosphate battery.
- Internal solid-state transfer switch automatically connects the internal battery to lamp heads for minimum 90-minute emergency illumination.
- Fully automatic solid-state, two rate charger initiates battery charging to recharge a discharged battery in 24 hours.
- Remote capacity of up to 3W available as a standard.

### MOUNTING

- Surface mount via easy connect back plate which fits most standard junction boxes.
- Suitable for wall or ceiling mount.
- Knockout for conduit applications.

### HOUSING

- Injection-molded, engineering grade, 5VA flame retardant, high-impact resistant, thermoplastic in white or black finish.

### WARRANTY / LISTING

- Five year warranty on all electronics and housing. Battery pro rated for two years.
- Meets UL924, NFPA 101 Life Safety Code, NEC, OSHA, Local and State Codes.
- UL Listed for damp locations (0°C – 50°C).



### DIMENSIONS

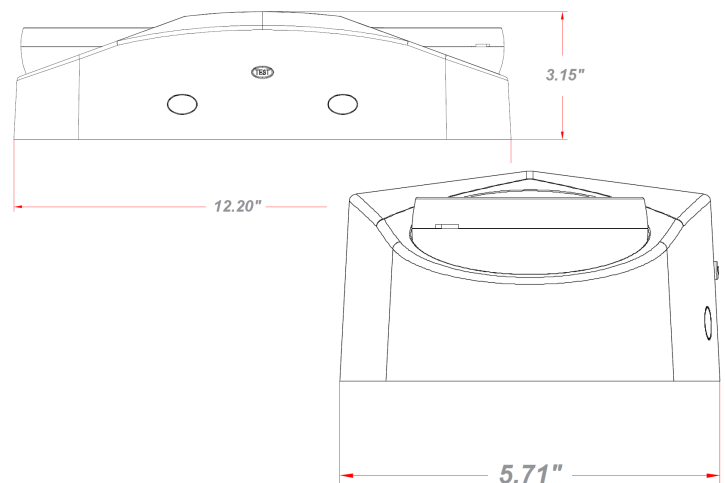

### SPACING

PART#	Mounting Height (FT)	3FT Width Egress Path		6FT Width Egress Path	
		Single Fixture (ft)	Fixture To Fixture (ft)	Single Fixture (ft)	Fixture To Fixture (ft)
LSHPEM	7.5 (Wall Mount)	100	100	90	90
	10 (Wall Mount)	84	88	78	82
	15 (Wall Mount)	80	83	72	76
	10 (Ceiling Mount)	102	105	90	96
	15 (Ceiling Mount)	100	101	86	90
	20 (Ceiling Mount)	88	91	82	85

### ORDERING INFORMATION

MODEL	HOUSING COLOR
LSHPEM	W White
	B Black

Sample Part Number:  
LSHPEMW